

Anchor-3000

The integrated seal with constructive shear load limitation by Cordes forms a unit with the pipe. For standard- and deep sockets, the **Anchor-3000** offers special advantages in terms of durability and long-term behavior of the pipe joint.

Advantages

The **Anchor-3000** seal is securely fixed in the pipe socket and lines it completely, thus forming a single constructional unit with the concrete pipe. This prevents seals from being faulty or left out completely.

- Constructive shear load limitation by integrated support collar of concrete and optimized elastomer
- Significantly improved long-term performance and durability of the pipe joint
- Reliable limiting of the shear load
- Controlled compression of the gasket
- Reduction of material creep / flow
- Optimized relaxation of restoring forces
- Radial circumferentially uniform compression of the seal, added safety tightness and root protection
- Proper installation and deflection of pipes
- Improved fixation of the seal during pipe insertion by integrated support collar
- Constructive strengthening of the sleeve
- Positive chamber effect of the sealing part by integrated support collar
- Pipe production in the concrete plant with existing formwork

The **Anchor-3000** seal is resistant against shear loads, root-proof and can withstand both internal and external pressure, as well as pressure from pipe cleaning.

The **Anchor-3000** seals are subject to permanent third-party monitoring by authorized institutions. They correspond to the requirements of EN 1916, EN 681-1, QR 4060 (FBS quality guideline) and other applicable quality standards.

Pipe production

Fit the **Anchor-3000** seal on the profiled pallet ring, make sure the seal fits properly. The pallet ring must be free of dirt in the area of the seal. Before the compression starts, the pipe form should be filled with concrete to above the area of the **Anchor-3000**.

Then produce the concrete pipe as usual. After production, place the inner and outer support ring on the spigot and release from the formwork together with the pallet ring only after the concrete has hardened. The pipe is ready for installation when the concrete is completely hardened.

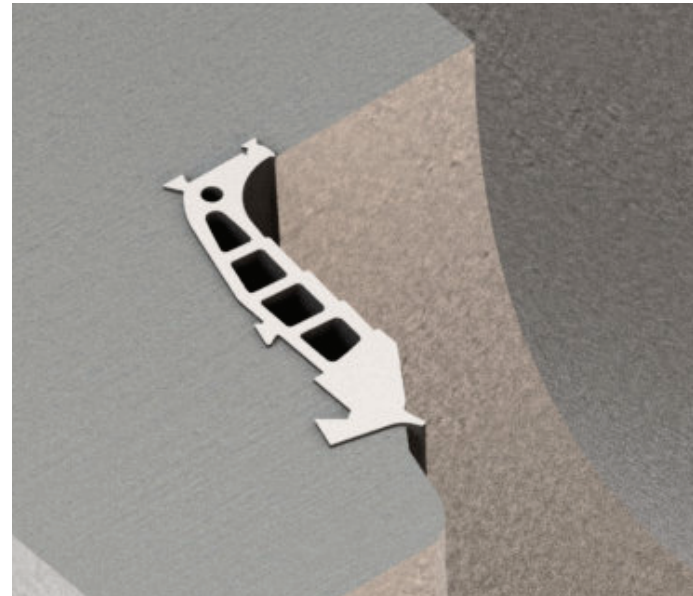

Field assembly

The necessary lubricant Cordes **GM-95** is applied liberally by hand to the spigot of the concrete pipe, starting at the radius.

Observe EN 1610 when laying the pipes.

Material

Anchor-3000 seals are fabricated from Ethylene-Propylene-Diene rubber (EPDM) and Styrene-Butadiene rubber (SBR). The use of these materials has proven its worth in rainwater and wastewater applications due to their excellent sealing characteristics.

Note: We recommend using seals made of Nitrile Butadiene rubber (NBR) for applications involving mineral fuels such as oils, petrol or similar.

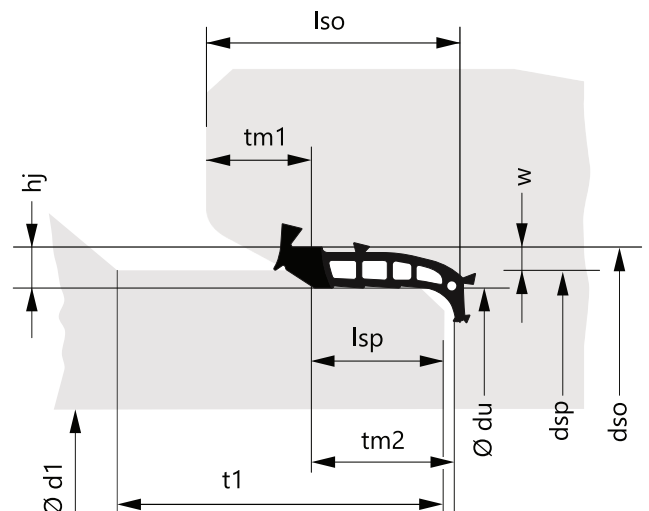

Anchor-3000 (Standard socket)

DN=ø d1	ø dsp	ø du	Isp	tm2	t1	tm1	Iso	hj	w
300 N	386.0	377.6	39	43.5	85	38.0	80	12	7.8 ± 1.2
300 S	404.0	395.6	39	43.5	85	38.0	80	12	7.8 ± 1.2
400 N	496.0	486.2	43	49.0	90	38.0	85	14	9.1 ± 1.4
400 S	505.3	495.5	43	49.0	90	38.0	85	14	9.1 ± 1.4
500	610.0	600.2	43	49.0	95	43.0	90	14	9.1 ± 1.4
600	726.0	716.2	43	49.0	95	43.0	90	14	9.1 ± 1.4
700	844.0	831.4	47	54.4	105	45.6	100	18	11.7 ± 1.8
800	962.0	949.4	47	54.4	105	45.6	100	18	11.7 ± 1.8
900	1080.0	1067.4	47	54.4	105	45.6	100	18	11.7 ± 1.8
1000	1198.0	1185.4	47	54.4	105	45.6	100	18	11.7 ± 1.8
1100	1316.0	1303.4	47	54.4	105	45.6	100	18	11.7 ± 1.8
1200	1434.0	1421.4	47	54.4	105	45.6	100	18	11.7 ± 1.8
1300	1552.0	1536.6	58	67.0	130	58.0	125	22	14.3 ± 2.2
1400	1670.0	1654.6	58	67.0	130	58.0	125	22	14.3 ± 2.2
1500	1788.0	1772.6	58	67.0	130	58.0	125	22	14.3 ± 2.2
1600	1760.2	1742.0	69	80.0	150	69.0	145	26	16.9 ± 2.6
1800	1960.2	1942.0	69	80.0	150	69.0	145	26	16.9 ± 2.6
2000	2183.8	2165.0	69	80.0	150	69.0	145	26	16.9 ± 2.6
2400	2602.2	2584.0	69	80.0	150	69.0	145	26	16.9 ± 2.6
2500	2712.2	2694.0	69	80.0	150	69.0	145	26	16.9 ± 2.6
2600	2822.2	2804.0	69	80.0	150	69.0	145	26	16.9 ± 2.6



Anchor-3000-L (Deep socket)

DN=ø d1	ø dsp	ø du	Isp	tm2	t1	tm1	Iso	hj	w
300	426.0	416.34	49	59.0	105	41.0	100	14	8.9 ± 1.4
400	526.0	516.34	49	59.0	105	41.0	100	14	8.9 ± 1.4
500	626.0	616.34	49	59.0	105	41.0	100	14	8.9 ± 1.4
600	726.0	716.34	49	59.0	105	41.0	100	14	8.9 ± 1.4
700	844.0	831.70	61	71.0	125	49.0	120	18	11.5 ± 1.8
800	962.0	949.70	61	71.0	125	49.0	120	18	11.5 ± 1.8
900	1080.0	1067.70	61	71.0	125	49.0	120	18	11.5 ± 1.8
1000	1198.0	1185.70	61	71.0	125	49.0	120	18	11.5 ± 1.8
1100	1316.0	1300.82	63	73.0	135	57.0	130	22	14.0 ± 2.2
1200	1434.0	1418.82	63	73.0	135	57.0	130	22	14.0 ± 2.2
1300	1552.0	1536.82	63	73.0	135	57.0	130	22	14.0 ± 2.2
1400	1670.0	1654.82	63	73.0	135	57.0	130	22	14.0 ± 2.2
1500	1788.0	1772.82	63	73.0	135	57.0	130	22	14.0 ± 2.2



We can also produce special sizes for both profiles upon request. Please call us or send us an e-mail.

Contents such as technical specifications, values and dimensions are given to the best of our knowledge, however, without any guarantee and liability. If not specified otherwise, dimensions are given in millimeters. Our General Terms and Conditions shall apply.